



NEXLER AQUAMINERAL 1K Ultra

Single-component sealing micro-mortar

TECHNICAL DATA

Ingredients	dry, polymer-modified cement mixture
Mixing ratio with water	1 : 0.22 ÷ 0.28 by weight (3.3 ÷ 4.2 l of water per a 15 kg bag)
Time of suitability for use after mixing the ingredients	60 mins
Maximum thickness of the applied layer	1 - 2 mm
Number of layers	min. 2
Time interval between applying individual layers	3 - 4 h
Initial tensile adhesion strength	≥ 0,5 N/mm ²
Water tightness	no penetration
Crack bridging ability	
• under standard conditions	≥ 0,75 mm
• at low temperature (-5°C)	≥ 0,75 mm
Durability of initial tensile adhesion against climate/heat ageing action:	
• tensile adhesion strength after heat ageing	≥ 0,5 N/mm ²
Durability of initial tensile adhesion against water/humidity action:	
• tensile adhesion strength after water contact	≥ 0,5 N/mm ²
Durability of initial tensile adhesion against contact with lime water	
• tensile adhesion strength after contact with lime water	≥ 0,5 N/mm ²
Durability of initial tensile adhesion against freeze and freeze-thaw cycles	
• tensile adhesion strength after freeze-thaw cycle	≥ 0,5 N/mm ²
Water vapour permeability	Class I (s _v < 5 m)
Capillary absorption and permeability to water	< 0,1 kg/m ² × h ^{0,5}
Adhesion strength by pull off test	≥ 0,8 (0,5) ^a N/mm ²
Permissible surface loading:	after approx.:
– with rain	– 12 h
– with pedestrian traffic	– 24 h
– with pressurised water	– 3 days
Backfilling the excavation	after approx. 3 days
Consumption:	
– per a 1 mm layer	approx. 1,5 kg/m ²
– damp-proof insulation	thickness of a bound coating 2 mm: 3,0 kg/m ²
– waterproof insulation (water not exerting pressure)	thickness of a bound coating 2,5 mm: 3,75 kg/m ²
– waterproof insulation (pressurised water)	thickness of a bound coating 3 mm: 4,5 kg/m ²
Substrate and ambient temperature during application and binding	from +8°C to +30°C
Reference documents	EN 14891:2012; EN 14891:2012/AC:2012; EN 1504-2:2004

^aThe value in brackets is the lowest accepted value of any reading.

PROPERTIES

- Resistant to negative water pressure
- Vapour-permeable
- Resistant to UV radiation
- Solvent-free
- Higienic Certificate



VAPOR PERMEABLE



RESISTANT TO UV RADIATION



RESISTANT TO THE NEGATIVE WATER PRESSURE

APPLICATION

- Waterproofing:
 - Damp-proof insulation and waterproofing of underground elements of buildings and structures in old and new buildings
 - Indoors against moisture penetrating from outside (tanking type)
- Horizontal waterproofing, especially where roll materials cannot be used (working gaps in monolithic structures)
- Sealing of tanks
- Sealing coatings under ceramic tiles, paint coatings and plasters



FOR INDOOR AND OUTDOOR USE



VERTICAL HORIZONTAL



SPRAYING DEVICE



TROWEL

PACKAGING

Poland

- Set: 15 kg
- Quantity per pallet:
- 15 kg - 56 sets

Export

- Set: 15 kg
- Quantity per pallet:
- 15 kg - 56 sets

METHOD OF USE

▪ CONDITIONS OF USE

The temperature of the substrate and air during the works should be from +8°C to +30°C.

Works should not be carried out during precipitation and strong sunlight.

▪ SUBSTRATE PREPARATION

Suitable substrates are: concrete, screeds, cement and cement-lime plasters, gypsum plaster boards, well jointed masonry. Do not apply to concrete sealed with crystallising mortars.

The substrate intended for product application must be clean, load-bearing, even, porous and seasoned. The substrate must not be frozen, frosty, stagnant water must not occur. The substrate should be cleaned mechanically, dust, any loose layers, sharp protruding edges and impurities that worsen adhesion should be removed. If there are cavities, honeycombing, gravel pockets and other unevenness in the substrate, it should be repaired, filled with suitable mortars from the NEXLER RENOBUD R series.

Special attention should be paid to the preparation of the substrate at the joints of elements (corners, joints of vertical and horizontal surfaces). Embed a sealing tape in all corners, e.g. sealing tape 120/120 or make a facet (rounding) with a radius of approx. 5 cm with a NEXLER RENOBUD R 103 mortar.

Immediately prior to application, the prepared mineral substrate should be slightly moistened, avoiding water stagnation. Substrates with a regular absorbency, dust-free do not require priming. Highly absorbent substrates and those containing gypsum require priming with NEXLER Gruntofol.

▪ PRODUCT PREPARATION

Pour the content of the bag into a clean container and mix with pure water until a homogenous consistency is obtained that is appropriate to be used with tools. Mix the material with water in a 1 to 0.22 – 0.28 l weight ratio (3.3 – 4.2 l of water per a 15 kg bag). The mixture prepared as described above should be used within 1 hour. The matured material cannot be stirred and processed again.

▪ APPLICATION METHOD

AQUAMINERAL 1K Ultra can be applied with a brush, trowel or spray equipment.

In order to close the pores in the substrate, it is necessary to rub in a first, thin layer with a brush. Before applying each successive layer (between applying successive layers), maintain a technological break of 3 - 4 hours for the layer to dry. The recommended application thickness per layer is 1 mm (no thicker than 2 mm).

During setting, the coating should be protected from precipitation, frost, overly rapid evaporation of water and large temperature differences for approx. 12 hours.

▪ CONTROL OF PERFORMANCE

Thickness of a layer should be checked by material consumption control on a dedicated surface. In addition, it is recommended to measure the thickness of the freshly applied sealing layer with special inspection plates. The measurement area should be filled with putty immediately.

After it has dried, a properly made coating should be a uniform, clean coating, without flakes and other defects. The coating should adhere closely to the substrate.

Particular attention should be paid to corners and areas where plumbing and other components pass through partitions – these need to be assessed for proper embedding of tapes, corners and cuffs.

The occurrence of colour variations or possible discolouration on the surface of the coating is related to the varying humidity of the air and substrate and to the varying thickness of the coating. This does not indicate a defect in the product and does not affect the quality of the applied layer.

TOOLS AND TOOL CLEANING

Slow speed stirrer, brush, masonry brush, steel trowel, spray equipment.

For spray application, we recommend using a spraying unit, e.g. Inotec InoBeam M8.

Wash tools with water during work and after their completion, and wipe dry. If the product dries, clean the tools mechanically. The bound material is difficult to remove.

Clean the spray equipment immediately after work, according to the manufacturer's instructions.

STORAGE AND TRANSPORT

The shelf life of the product is 12 months from production date.

Store in dry and cool rooms at temp. from +5°C to +25°C, in tightly sealed, original packaging. Protect the material from water and moisture. The product is sensitive to negative temperatures.

NOTES

Works should be carried out in accordance with technical conditions, manufacturer's instructions, health and safety standards and regulations.

For information on how to deal with symptoms of disease, allergies or irritation of the skin or eyes, please refer to the Safety Data Sheet (www.nexler.com).

The remaining content of the product and container should be handed over to authorized companies.

GENERAL RECOMMENDATIONS

Technical data and information on the method of use are given for a temperature of 23°C ± 2°C and a relative air humidity of 55%. In other conditions, the setting (drying) time may change significantly.

The consumption of the product given in this sheet depends on the preparation of the substrate.

SAFETY INFORMATION

Causes skin irritation. May cause an allergic skin reaction. Causes serious eye damage. May cause respiratory irritation. If medical advice is needed, have product container or label at hand. Keep out of reach of children. Wash hands and exposed parts of the body thoroughly after handling. Wear protective gloves/protective clothing/eye protection/face protection. IF IN EYES: Rinse cautiously with water for several minutes. Remove contact lenses, if present and easy to do. Continue rinsing. Dispose of contents/container to according to the instructions of the manufacturer or person authorized to dispose of waste.

IMPORTANT INFORMATION

Please refer to the detailed conditions of use of the product before use.

We guarantee the quality of our materials as part of our terms of sale and delivery.

For buildings with special requirements that are not covered by this manual, we provide our Customers with our own professional advisory service.

The manufacturer has no influence on the improper use of the material, its use for other purposes or under conditions other than those described above. The guarantee only covers the quality of the delivered product. The correct and therefore effective use of the product is not subject to our control.

Neither the manufacturer nor his authorized representative may be held liable for any loss incurred as a result of improper use or storage of the product.

Employees of the company are authorized to provide technical information only and solely in accordance with this technical data sheet. Information other than that contained in this sheet should be confirmed in writing.

If you have any doubts, consult the manufacturer.

Once we have issued a new technical data sheet, this manual is no longer valid.

CONTACT DETAILS

NEXLER sp. z o.o.

Łużycka 6, 81-537 Gdynia, Poland

tel.: +48 58 712 94 44

www.nexler.com

e-mail: dt@nexler.com

DETAILS

Detail of footing and foundation wall connection

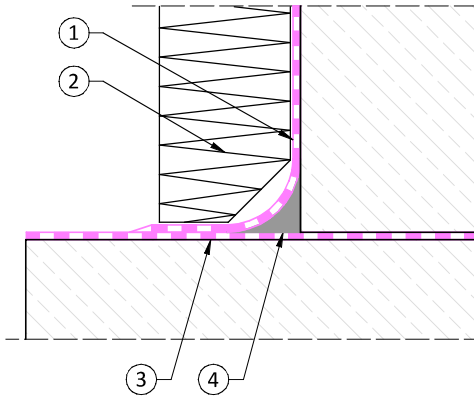

1. Vertical waterproofing – **NEXLER AQUAMINERAL 1K Ultra**
2. Thermal insulation – XPS or EPS boards bonded with NEXLER BITFLEX 1KP
3. Horizontal waterproofing - **NEXLER AQUAMINERAL 1K Ultra**
4. A facet made of NEXLER RENOBUD R 103

Detail of the sealing of an installation pipe passage through a foundation wall

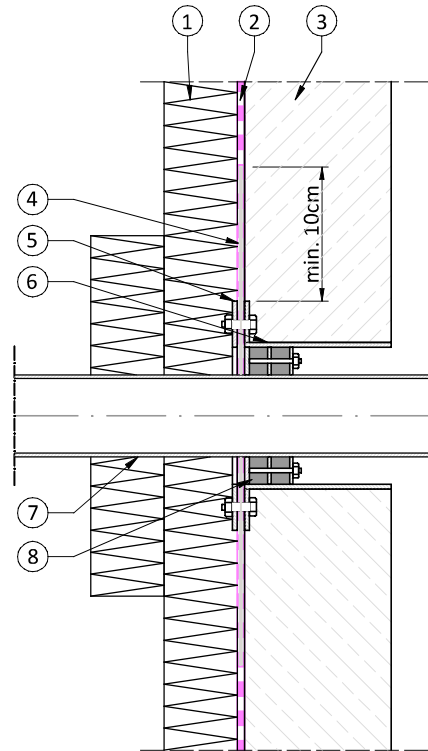

1. Thermal insulation – XPS or EPS boards bonded with NEXLER BITFLEX 1KP
2. Vertical waterproofing – **NEXLER AQUAMINERAL 1K Ultra**
3. Foundation wall
4. Sealing sleeve
5. Movable flange
6. Fixed flange
7. Installation pipe
8. Sealing chain