



NEXLER EPOLIS EP 602

Two-component epoxy membrane

TECHNICAL DATA

| | |
|---|--|
| Ingredients: | |
| - component A | epoxy resin, filler, colour, additives |
| - component B | hardener |
| Colour | light grey 7040 |
| Density: | |
| - składnik A | 1,14 - 1,26 g/cm ³ |
| - składnik B | 0,94 - 1,04 g/cm ³ |
| Mixing ratio | 1: 0,54 by weight (component A : component B) |
| Recommended number of layers: | |
| - paintbrush | 2 |
| - steel trowel | 1 with a thickness of 2 mm |
| Open time | 45 min |
| Time interval between applying individual layers | 24 h |
| Full hardening time of the coating | 7 days |
| Pedestrian traffic load | after 24 h |
| Reaction to fire | E ₁ |
| Mechanical resistance | |
| Wear resistance | ≤ AR1 |
| Bond strength | ≥ B1,5 |
| Impact resistance | ≥ IR4 |
| Resistance to peeling off the substrate, pull-off method¹⁾ | ≥ 2,0 MPa |
| Resistance to peeling off a concrete substrate after 200 freeze-thaw cycles in water at a temp. of -18/+18°C, pull-off method¹⁾ | ≥ 1,5 MPa |
| Assessment of the coating condition on a concrete substrate after 200 freeze-thaw cycles in water at a temp. of -18°C / +18°C¹⁾ | no changes |
| Abrasion tested on a Böhme disc¹⁾ | ≤ 12500 mm ³ / 5000 mm ² |
| Resistance to peeling off a steel substrate, pull-off method²⁾ | ≥ 2,5 MPa |
| Resistance to peeling off a steel substrate after 200 freeze in air and thaw in water cycles in water at a temp. of 18/+18°C, pull-off method²⁾ | ≥ 2,0 MPa |
| Assessment of the coating condition on a steel substrate after 200 freeze-thaw cycles in water at a temp. of -18°C/ +18°C²⁾ | no changes |
| Water vapour permeability, Sd | 30 m (class II) |
| Water absorption reduction rate | ≥ 90% |

| | |
|--|--|
| Resistance of the coating to exposure to: | |
| - diesel fuel over a period of 144 h, with a temp. of 20 ± 2°C | no changes in the coating |
| - salt spray over a period of 144 h | no changes in the coating |
| Elongation | 93% |
| Elongation at -10°C | 75% |
| Temperature of use | from +15°C to +30°C |
| Relative air humidity | max. 70% |
| Consumption: | |
| - coating without sand | 1,0 - 1,2 kg/m ² |
| - insulation-pavement: | |
| • on traffic routes with a pedestrian traffic load | 1,6 kg/m ² EPOLIS EP 602 + 1,6(*) kg/m ² of sand min. 2 mm thickness |
| • on traffic routes with a low vehicular traffic load | 2,4 kg/m ² EPOLIS EP 602 + 2,4(*) kg/m ² of sand min. 3 mm thickness |
| • on traffic routes with a vehicular traffic load | 4,0 kg/m ² EPOLIS EP 602 + 4,0(*) kg/m ² of sand min. 5 mm thickness |
| Available versions | Pourable Vertical/Horizontal |
| Reference document(s) | EN 13813:2002 |

¹⁾ For application on a concrete substrate

²⁾ For application on a steel substrate

PROPERTIES

- Very good adhesion to substrate
- Creates a coating resistant to mechanical stress (abrasion, impact)
- Resistant to acidic or alkaline chemical substances
- Resistant to water and marine and industrial atmospheres, oils, petrol etc.
- Allows for creating a pavement with high resistance to abrasion (after being mixed with quartz sand)



WATERPROOF



MECHANICAL RESISTANT



CHEMICAL RESISTANT

APPLICATION

- For protecting pedestrian routes and routes with vehicular traffic load (e.g. multi-stand garages, production halls)
- For protecting concrete structures and steel elements in industrial and construction areas and ballast and wastewater tanks, e.g. in municipal and industrial wastewater treatment plants, in inland hydraulic engineering and marine construction



POURABLE



VERTICAL/HORIZONTAL



VELOUR ROLLER



STEEL TROWEL

PACKAGING

Poland

- Packaging set: 20 kg (13 kg + 7 kg)

Export

- Packaging set: 20 kg (13 kg + 7 kg)

METHOD OF APPLICATION

CONDITIONS OF USE

The work should be carried out at an ambient temperature of +15 to +30°C, with a maximum relative humidity of 70%. Higher temperatures and humidity accelerate the setting time of the mix. At lower temperatures, a delay in setting is to be expected, as well as a change in the consistency of the material and as a result of that an increase in consumption. The temperature of the substrate must always be at least 3°C above the dew point temperature until the material is fully cured.

Works should not be carried out during precipitation and strong sunlight.

The premises where the work takes place must be sectioned off, protected from unauthorised access and a safety zone must be maintained against the use of open flames, particularly before conducting welding work. During the works, very good ventilation of the work area should be ensured.

SUBSTRATE PREPARATION

The concrete substrate must be made of concrete of min. C20/25 grade, with a strength of at least 1,5 MPa measured by the pull-off method. The substrate must be stable, continuous, even, bonded, seasoned and dry. It must be clean and free of oil, grease, cement laitance and other substances that impair adhesion. The substrates should be cleaned mechanically, dust, any loose layers and sharp protruding edges should be removed.

Steel surfaces should be cleaned of rust and other impurities to a cleanliness grade of Sa 2½.

Prime the substrate with the NEXLER EPOLIS EP 601 product. After the primer has dried, no later than after 24 hours, apply the EPOLIS EP 602 membrane.

PRODUCT CONTROL

Check the production date on the packaging before use. The product should not be incorporated beyond its shelf life. The product should not be objectionable after opening and should not contain any mechanical impurities. After mixing, the compound should be homogeneous and free of lumps.

PRODUCT PREPARATION

Components A and B are supplied in a proper mixing ratio. Mix component A in the delivery vessel in order to homogenise and evenly distribute the mineral filler and colorant. Then add the total amount of ingredient B and mix with a mechanical stirrer at 300 - 600 rotations per minute for approximately 3 minutes. While mixing, scrape the mixture from the sides and bottom of the vessel with the mixer to ensure thorough distribution of the hardener. After mixing, pour the material into the working vessel and mix again.

With traffic load, after mixing components A and B, gradually add quartz sand with a grain size of 0,8 - 1,2 mm at a weight ratio of 1 : 1. Mix the ingredients until a homogeneous consistency is obtained (approx. 3 minutes). Pour the mixed material into a clean container and mix again.

If partial use is assumed, the product should be prepared maintaining the weight ratio of the components (1 part component A and 0,54 of component B).

The permissible application time of the mixed material at a temperature of +20°C is up to 45 min.

APPLICATION METHOD

The coating can be applied by a brush, roller or steel trowel.

Bear in mind that the height of the notches depends on the required layer thickness. After unfolding, immediately level the surface with a spiked roller to deaerate the membrane. The recommended thickness of the coating applied in one working operation is 2 - 3 mm. In the case of heavy loading, an additional backfilling of quartz grit with a grain size of 0,8 - 1,2 mm, in an amount of 2,0 - 2,5 kg/m², is recommended. Apply the grit to the still fresh, unbound membrane. After 24 hours, sweep up the excess grit.

The interval between the application of layers of EPOLIS EP 602, or any other resin, should be approximately 24 hours. The application of subsequent layers of the membrane after a period of more than 24 hours should be preceded by degreasing, sanding the coating with fine-grained sandpaper or lightly sandblasting, drying and dusting.

▪ CONTROL OF PERFORMANCE

When fresh, check the consumption of the material per unit and/or dedicated area on an ongoing basis.

The appearance of the completed coating depends on the ambient temperature and humidity, the absorbency of the substrate and the method of application.

The bonded coating should have a uniform texture, without bulges, air bubbles, wrinkles or cracks.

Particular batches of the product may differ slightly in the shade of colour. It should be ensured that the architecturally separated surfaces of the substrate are covered with resin from one production batch.

▼ TOOLS AND TOOL CLEANING

Velour roller with short bristles, paint brush, steel trowel, spiked roller, low-speed stirrer.

Before using the roller for the first time, loose hair should be removed from the roller, e.g. by wrapping it with self-adhesive painter's tape and then peeling off the tape.

Clean tools with acetone or xylene immediately after use (resin must be in an unbound state). After the resin dries, clean tools mechanically.

▼ STORAGE AND TRANSPORT

The shelf life of the product is 12 months from production date specified on the packaging. Store in dry and airy rooms at temp. from +10°C to +25°C in tightly sealed, original packaging. Protect the product from heat and exposure to direct sunlight. The product should only be transported by covered means of transport. Prior to application, **EPOLIS EP 602** should be seasoned for at least 24 hours in a room with a minimum temperature of 15°C.

▼ NOTES

Works should be carried out in accordance with technical conditions, manufacturer's instructions, health and safety standards and regulations.

For information on how to deal with symptoms of disease, allergies or irritation of the skin and eyes, please refer to the Material Safety Data Sheet (www.nexler.com).

The remaining content of the product and container should be handed over to authorized companies.

▼ GENERAL RECOMMENDATIONS

Technical data and information on the method of use are given for a temperature of 23°C ± 2°C and a relative air humidity of 55%. In other conditions, the setting (drying) time may change significantly.

The consumption of the product given in this sheet depends on the preparation and type of the substrate.

Despite the high UV resistance, the possibility of discolouration

occurring due to exposure to sunlight must be taken into account. Discolouration does not affect the mechanical properties and does not constitute a defect.

Individual batches of the product may vary in shade of colour. Ensure that architecturally separated substrate surfaces are coated with resin from the same production batch.

Coatings of this type are "sensitive" products and must be handled very carefully with attention to all elements that may affect the quality and appearance of the coating being applied.

In systems using aggregate, use dried, fractionated quartz aggregates that have been washed and dusted.

The user of the product is obliged to use it in accordance with its intended use and recommendations. In all cases, it is recommended to carry out an appropriate test.

▼ SAFETY INFORMATION

Component A: Causes skin irritation. May cause an allergic skin reaction. Causes serious eye irritation. Toxic to aquatic life with long lasting effects. Precautionary statements. If medical advice is needed, have product container or label at hand. Keep out of reach of children. Wash hands and exposed parts of the body thoroughly after handling. Wear protective gloves/protective clothing/eye protection/face protection. Collect spillage. Dispose of contents/container to according to the instructions of the manufacturer or person authorized to dispose of waste.

Component B: Harmful if swallowed. Causes severe skin burns and eye damage. May cause an allergic skin reaction. Very toxic to aquatic life with long lasting effects. Precautionary statements. If medical advice is needed, have product container or label at hand. Keep out of reach of children. Wear protective gloves/protective clothing/eye protection/face protection. IF SWALLOWED: Rinse mouth. Do NOT induce vomiting. IF ON SKIN (or hair): Take off immediately all contaminated clothing. Rinse skin with water or shower. IF IN EYES: Rinse cautiously with water for several minutes. Remove contact lenses, if present and easy to do. Continue rinsing. Immediately call a doctor. Collect spillage. Dispose of contents/container to according to the instructions of the manufacturer or person authorized to dispose of waste.

▼ IMPORTANT INFORMATION

Please refer to the detailed conditions of use of the product before use. We guarantee the quality of our materials as part of our terms of sale and delivery. For buildings with special requirements that are not covered by this manual, we provide our Customers with our own professional advisory service.

The manufacturer has no influence on the improper use of the material, its use for other purposes or under conditions other than those described above. The guarantee only covers the quality of the delivered product. The correct and therefore effective use of the product is not subject to our control.

Neither the manufacturer nor his authorized representative may be held liable for any loss incurred as a result of improper use or storage of the product.

Employees of the company are authorized to provide technical information only and solely in accordance with this Technical Data Sheet. Information other than that contained in this sheet should be confirmed in writing.

If you have any doubts, consult the manufacturer.

CONTACT DETAILS

NEXLER sp. z o.o.

Łużycka 6, 81-537 Gdynia, Poland

tel.: +48 58 712 94 44

www.nexler.com

e-mail: dt@nexler.com

ISSUE DATE

This Technical Data Sheet was issued on 17.02.2025.

Once we have issued a new Technical Data Sheet, this one is no longer valid.

DETAILS

Detail of floor expansion joint - case of predominantly pedestrian traffic load

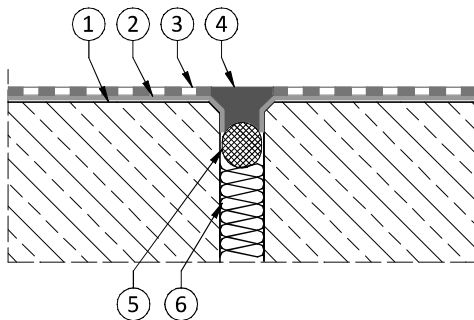

1. Reinforced concrete substrate
2. NEXLER EPOLIS EP 601 epoxy primer
3. Epoxy coating **NEXLER EPOLIS EP 602** with a topping of quartz aggregate
4. Filling of the expansion joint - NEXLER EPOLIS EP 603 Horizontal
5. NEXLER Backer Rod with a diameter 20% bigger than the width of the gap
6. Polystyrene filling

Detail of floor expansion joint - case of intense mechanical traffic load

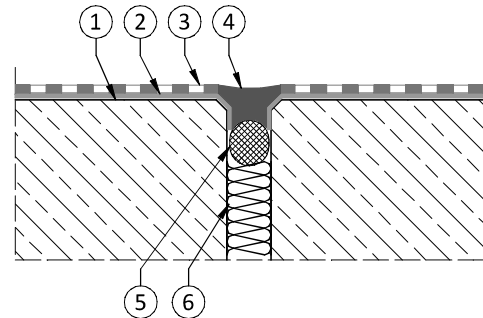

1. Reinforced concrete substrate
2. NEXLER EPOLIS EP 601 epoxy primer
3. Epoxy coating **NEXLER EPOLIS EP 602** with a topping of quartz aggregate
4. Filling of the expansion joint - NEXLER EPOLIS EP 603 Horizontal
5. NEXLER Backer Rod with a diameter 20% bigger than the width of the gap
6. Polystyrene filling

Detail of floor expansion joint - expansion joint in the plinth area

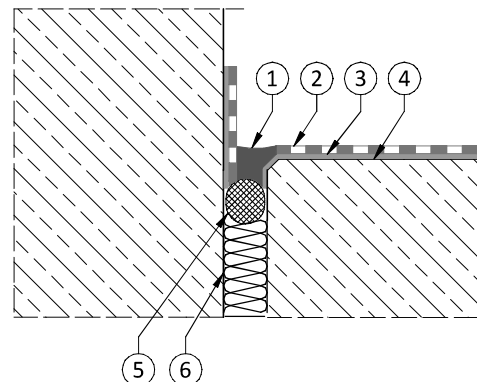

1. Filling of the expansion joint - NEXLER EPOLIS EP 603 Horizontal
2. Epoxy coating **NEXLER EPOLIS EP 602** with a topping of quartz aggregate
3. NEXLER EPOLIS EP 601 epoxy primer
4. Reinforced concrete substrate
5. NEXLER Backer Rod with a diameter 20% bigger than the width of the gap
6. Polystyrene filling