



NEXLER EPOLIS EP 603

Epoxy sealant

TECHNICAL DATA

Ingredients:		
- component A	epoxy resin, filler, pigment, additives	
- component B	hardener	
- component C	rheological additive	
Colour	light gray 7040	
Density	1,2 g/cm ³	
Mixing ratio (by weight):		
- Vertical	1 : 0,54 : 0,06 (component A : component B : component C)	
- Horizontal	1 : 0,54 (component A : component B)	
Time of suitability for use after mixing the ingredients	45 mins	
Initial drying time	approx. 6 h (skinning)	
Full hardening time of the coating	7 days	
Pedestrian traffic load	after 24 h	
Elastic recovery	≥ 40%	
Tensile properties at maintained extension	no failure	
Adhesion/cohesion properties at variable temperatures	no failure	
Adhesion/cohesion properties at maintained extension after water immersion	no failure	
Loss of volume	≤ 25%	
Resistance to flow	≤ 3 mm	
Breaking load	approx. 350 N	
Elongation at break	≥ 60%	
Amplitude	± 12,5%	
Temperature of use	from +15°C to +30°C	
Relative air humidity	max. 70%	
Consumption		
	gap dimension	consumption in kg/LM
	width [mm] depth [mm]	
	5 5	0,035
	6 6	0,05
	8 8	0,09
	10 10	0,14
	12 12	0,225
	15 8	0,30
	20 10	0,35
	25 12	0,40
	30 15	0,54
Reference document	PN-EN ISO 11600:2004, PN-EN ISO 11600:2004/A1:2011	
Available versions	Vertical Horizontal	

PROPERTIES

- Very good adhesion to substrates made of concrete, ceramic cladding and resin flooring
- Creates a coating resistant to mechanical stress (abrasion, impact)
- Resistant to acidic or alkaline chemical media
- Resistant to water and marine and industrial atmospheres
- Resistant to impact of domestic wastewater (wastewater treatment plants)

APPLICATION

- For filling expansion joints with a width from 5 to 35 mm on vertical surfaces (NEXLER EPOLIS EP 603 Vertical version) and horizontal surfaces (NEXLER EPOLIS EP 603 Horizontal version) inside and outside buildings
- For closing scratches and cracks on vertical
- For closing scratches and cracks on horizontal surfaces, also with a vehicular traffic load



VERTICAL

HORIZONTAL

PACKAGING

EPOLIS EP 603 Vertical

- Packaging set: 2 kg (1,3 kg + 0,7 kg + 0,075 kg)

EPOLIS EP 603 Horizontal

- Packaging set: 2 kg (1,3 kg + 0,7 kg)

METHOD OF USE

CONDITIONS OF USE

The work should be carried out at an ambient temperature of from +15 to +30°C, with a maximum relative humidity of 70%. Higher temperatures and humidity accelerate the setting time of the mix. At lower temperatures, a delay in setting is to be expected, as well as a change in the consistency of the material and as a result of that an increase in consumption. The temperature of the substrate must always be at least 3°C above the dew point temperature until the material is fully cured.

Works should not be carried out during precipitation and strong sunlight.

The premises where the work takes place must be sectioned off, protected from unauthorised access and a safety zone must be maintained against the use of open flames, particularly before conducting welding work. During the works, very good ventilation of the work area should be ensured.

SUBSTRATE PREPARATION

The concrete substrate must be made of concrete of min. C20/25 grade, with a strength of at least 1.5 MPa measured by the pull-off method. The substrate must be stable, continuous, even, bonded, seasoned. It must be clean and free of oil, grease, cement laitance and other substances that impair adhesion. The substrates should be cleaned mechanically, dust, any loose layers and sharp protruding edges should be removed. The substrate should be in an air-dry condition, without any visible traces of moisture or darkening caused by moisture.

The areas of scratches and cracks should first be incised with an angle grinder to a depth of approximately 2 cm along the crack and transversely, in sections of approximately 15 cm, at approximately 25 cm intervals. The incisions need to be vacuumed thoroughly.

Steel surfaces should be cleaned of rust and other impurities to a cleanliness grade of Sa 2½.

Prime the sides of gap with the NEXLER EPOLIS EP 601 product. After the primer has dried, no later than after 24 hours, apply the EPOLIS EP 603 epoxy membrane.

PRODUCT PREPARATION

Components A and B are supplied in a proper mixing ratio.

EPOLIS EP 603 Horizontal: Mix component A in the delivery vessel in order to homogenise and evenly distribute the mineral filler and dye. Then add the total amount of ingredient B and mix with a mechanical stirrer at 300 - 600 rpm for approximately 3 minutes. While mixing, scrape the mixture from the sides and bottom of the vessel with the mixer to ensure thorough distribution of the hardener.

EPOLIS EP 603 Vertical: Prepare the product in accordance with the instructions on the EPOLIS EP 603 Horizontal version, then add the powder component C and mix the ingredients again with a stirrer for approximately 3 minutes. If the compound heats up, wait 5 - 10 minutes until it returns to ambient temperature.

Pour the entire mixture into the bottle of component B. Cut off the application tip located on the bottle cap.

If partial use is assumed, the product should be prepared maintaining the weight ratio of the components (1 part component A and 0.54 of component B or 1 part component A, 0.54 of component B and 0.06 of component C).

The permissible application time of the mixed material at a temperature of +20°C is up to 45 min.

APPLICATION METHOD

The product is applied by squeezing from the bottle.

Sealing of the expansion joint: The bottom horizontal surface of the joint should be filled with an expansion cord to which the sealants do not adhere. EPOLIS EP 603 should be placed in the joint in such a way (bond adhesives, sealants, movable joints) that it only makes contact with the two vertical surfaces of the joint. The width A and depth B of the seal should be min. 5 mm. Expansion cord should have a diameter 20% bigger than the width of the gap. With wide expansion joints $A > 12$ mm, the depth B should be half the width $A : B = 2 : 1$.

Closing scratches, cracks: Scratches and cracks should be closed forcibly. Pour the EPOLIS EP 603 epoxy resin over appropriately widened and cleaned cracks, and, additionally, place steel reinforcement inserts in the transverse cuts. Before the resin starts to bind, sprinkle the filled in joint with clean, dry sand.

Freshly filled in joints should be protected against water exposure for at least 8 hours.

CONTROL OF PERFORMANCE

The bonded coating should have a uniform texture, without bulges, air bubbles, wrinkles or cracks. Particular attention must be paid to the proper filling of the expansion joint with expansion cord so that the material only comes into contact with the vertical surfaces of the joint.

TOOLS AND TOOL CLEANING

Slow stirrer.

Clean tools with acetone or xylene immediately after use (resin must be in an unbound state). After the resin dries, clean tools mechanically.

STORAGE AND TRANSPORT

The shelf life of the product is 12 months from production date. Store in dry and airy rooms at temperature from +10°C to +25°C in tightly sealed, original packaging. Protect the product from heat and exposure to direct sunlight. The product should only be transported by covered means of transport. Prior to application, **EPOLIS EP 603** should be seasoned for at least 24 hours in a room with a minimum temperature of 15°C.

NOTES

Works should be carried out in accordance with technical conditions, manufacturer's instructions, health and safety standards and regulations.

For information on how to deal with symptoms of disease, allergies or irritation of the skin and eyes, please refer to the Safety Data Sheet (www.nexler.com).

The remaining content of the product and container should be handed over to authorized companies.

GENERAL RECOMMENDATIONS

Technical data and information on the method of use are given for a temperature of 23°C ± 2°C and a relative air humidity of 55%. In other conditions, the setting (drying) time may change significantly.

The consumption of the product given in this sheet depends on the preparation and type of the substrate.

Coatings of this type are "sensitive" products and must be handled very carefully with attention to all elements that may affect the quality and appearance of the coating being applied.

In systems using aggregate, use dried, fractionated quartz aggregates that have been washed and dusted.

The user of the product is obliged to use it in accordance with its intended use and recommendations. In all cases, it is recommended to carry out an appropriate test.

SAFETY INFORMATION

Component A: Causes skin irritation. May cause an allergic skin reaction. Causes serious eye irritation. Toxic to aquatic life with long lasting effects. If medical advice is needed, have product container or label at hand. Keep out of reach of children. Wash hands and exposed parts of the body thoroughly after handling. Wear protective gloves/protective clothing/eye protection/face protection. Collect spillage. Dispose of contents/container to according to the instructions of the manufacturer or person authorized to dispose of waste.

Component B: Harmful if swallowed. Causes severe skin burns and eye damage. May cause an allergic skin reaction. Very toxic to aquatic life with long lasting effects. If medical advice is needed, have product container or label at hand. Keep out of reach of children. Wear protective gloves/protective clothing/eye protection/face protection. IF SWALLOWED: Rinse mouth. Do NOT induce vomiting. IF ON SKIN (or hair): Take off immediately all contaminated clothing. Rinse skin with water or shower. Rinse cautiously with water for several minutes. Remove contact lenses, if present and easy to do. Continue rinsing. Immediately call a doctor. Collect spillage. Dispose of contents/container to according to the instructions of the manufacturer or person authorized to dispose of waste.

Component C: Do not breathe dust. In case of inadequate ventilation wear respiratory protection.

IMPORTANT INFORMATION

Please refer to the detailed conditions of use of the product before use. We guarantee the quality of our materials as part of our terms of sale and delivery.

For buildings with special requirements that are not covered by this manual, we provide our Customers with our own professional advisory service.

The manufacturer has no influence on the improper use of the material, its use for other purposes or under conditions other than those described above. The guarantee only covers the quality of the delivered product. The correct and therefore effective use of the product is not subject to our control.

Neither the manufacturer nor his authorized representative may be held liable for any loss incurred as a result of improper use or storage of the product.

Employees of the company are authorized to provide technical information only and solely in accordance with this technical data sheet. Information other than that contained in this sheet should be confirmed in writing.

If you have any doubts, consult the manufacturer.

Once we have issued a new technical data sheet, this manual is no longer valid.

DETAILS

Detail of floor expansion joint - case of predominantly pedestrian traffic load

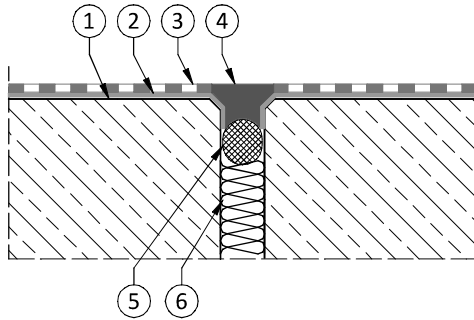

1. Reinforced concrete substrate
2. NEXLER EPOLIS EP 601 epoxy primer
3. NEXLER EPOLIS EP 602 epoxy coating with a topping of quartz aggregate
4. Filling of the expansion joint - **NEXLER EPOLIS EP 603 Horizontal**
5. NEXLER Expansion Cord with a diameter 20% bigger than the width of the gap
6. Polystyrene filling

Detail of floor expansion joint - expansion joint in the plinth area

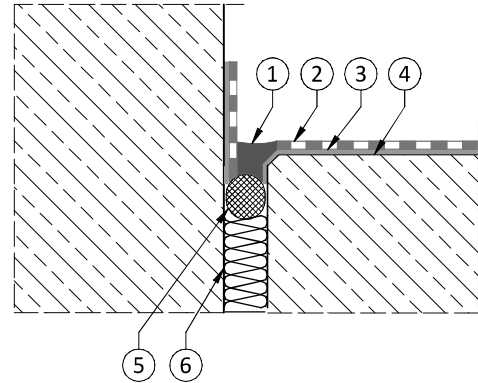

1. Filling of the expansion joint - **NEXLER EPOLIS EP 603 Horizontal**
2. NEXLER EPOLIS EP 602 epoxy coating with a topping of quartz aggregate
3. NEXLER EPOLIS EP 601 epoxy primer
4. Reinforced concrete substrate
5. NEXLER Expansion Cord with a diameter 20% bigger than the width of the gap
6. Polystyrene filling

Detail of floor expansion joint - case of intense mechanical traffic load

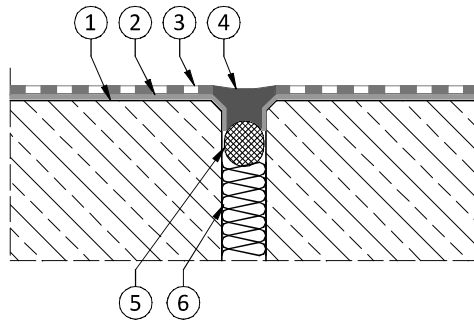

1. Reinforced concrete substrate
2. NEXLER EPOLIS EP 601 epoxy primer
3. NEXLER EPOLIS EP 602 epoxy coating with a topping of quartz aggregate
4. Filling of the expansion joint - **NEXLER EPOLIS EP 603 Horizontal**
5. NEXLER Expansion Cord with a diameter 20% bigger than the width of the gap
6. Polystyrene filling

Detail of vertical expansion joint of the wall

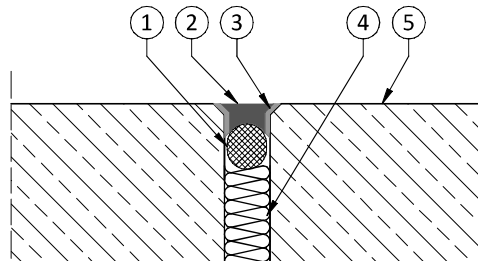

1. NEXLER Expansion Cord with a diameter 20% bigger than the width of the gap
2. Filling of the expansion joint - **NEXLER EPOLIS EP 603 Vertical**
3. NEXLER EPOLIS EP 601 epoxy primer
4. Polystyrene filling
5. Reinforced concrete wall